

GE Infrastructure
Sensing

Models:
M3830; M3840; M3860

High Pressure Hydraulic Deadweight Tester



imagination at work

WARRANTY

GE Infrastructure Sensing warrants its products to conform to or exceed the specifications as set forth in its catalogs in use at the time of sale and reserves the right, at its own discretion, without notice and without making similar changes in articles previously manufactured, to make changes in materials, designs, finish, or specifications.

GE Infrastructure Sensing warrants products of its own factory against defects of material or workmanship for a period of one year from date of shipment.

Liability of GE Infrastructure Sensing under this warranty shall be limited to replacing, free of charge (FOB Houston, Texas), any such parts proving defective within the period of this warranty, but will not be responsible for transportation charges or consequential damages.

This warranty is not made for products manufactured by others which are illustrated and described in GE Infrastructure Sensing catalogs or incorporated in GE Infrastructure Sensing products in essentially the same form as supplied by the original manufacturer. However, GE Infrastructure Sensing agrees to use its best efforts to have original suppliers make good their warranties.

COPYRIGHT NOTICE

Copyright © 2005 by GE Infrastructure Sensing. All rights reserved. This document may not be reproduced in part or in whole without the express written consent of GE Infrastructure Sensing.

WARNING

PRESSURIZED VESSELS AND ASSOCIATED EQUIPMENT ARE POTENTIALLY DANGEROUS. THE APPARATUS DESCRIBED IN THIS MANUAL SHOULD BE OPERATED BY PERSONNEL TRAINED IN PROCEDURES THAT WILL ASSURE SAFETY TO THEMSELVES, TO OTHERS, AND TO THE EQUIPMENT.

DISCLAIMER

No representations or warranties are made with respect to the contents of this user's manual. Further, GE Infrastructure Sensing reserves the right to revise this manual and to make changes from time to time in the content hereof without obligation to notify any person of such revision.

REVISION NOTICE

RELEASE NUMBER	REVISION	DATE OF REVISION	DESCRIPTION
PMAN-154-1D01	A	05/12/05	Original release.

Please read these instructions carefully prior to installing and using the Tester. The pressure built up internally during use can be extremely high. Ensure that all connections are made correctly.

DO NOT CONNECT DWT TO EXTERNAL PRESSURE SOURCE

1.0 GENERAL INFORMATION

The M3800 Series of Deadweight Testers (DWT) provides a convenient means of testing High Pressure instruments for calibration accuracy.

The design incorporates the "PISTON GAUGE" principle, in which an applied pressure within the system, balances a known mass applied to a piston of known effective area. i.e.

$$PRESSURE = \frac{\text{Total mass applied to piston}}{\text{Effective area of piston}}$$

The unit comprises a Base Plate onto which is mounted a High Pressure Manifold, a Piston/Cylinder Unit (PCU), a Test Station (to mount the Item Under Test), a Fluid Reservoir, a Ram Screw pressure generating system, a Pressure Intensifier (which increases the pressure generated by a factor of 7:1), and a Safety Relief Valve (which protects both the Low and High Pressure Systems from accidental overpressure). The whole assembly is contained within a strong GRP housing.

The unit is equipped with four adjustable feet to enable correct leveling. This ensures that the PCU is in the vertical plane, which is essential for both accurate and reliable performance.

The hydraulic fluid supplied with the unit has been specially formulated to remain fluid at High Pressures and to ensure no corrosion of internal parts. In addition the fluid will not oxidize in contact with air or emulsify or mix with water.

2.0 PREPARATION

Note: Item number references in the following text, (1), (2), etc, relate to the hydraulic system schematic, shown in Figure 1.

2.1 LOCATION

Place the unit onto a clean, flat surface of a strong and rigid work bench.

Ensure that the front of the unit is approximately $\frac{3}{4}$ " / 20 mm from the front edge of the bench to allow the Ram Screw Capstan to overhang and freely rotate.

Level the DWT by placing the Spirit Level on top of the Carrier Tube and adjusting the 4 leveling feet accordingly.

2.2 FLUID FILLING

Fill the Fluid Reservoir as follows :-

Fully unscrew (counter-clockwise) the Reservoir Valve Screw (3) and remove it together with the spring and reservoir cover. Place to one side. Fill with the correct fluid to the top of the brass nut visible on the inside of the reservoir. Fully wind out (counter-clockwise) the Capstan so that fluid is drawn into the DWT. Refill the Reservoir to the top of the brass nut and replace the cover, spring and Reservoir Valve Screw. Fully screw in (clockwise) the Reservoir Valve Screw and then unscrew (counter-clockwise) again 4 full turns.

The deadweight tester is now ready to receive the Equipment Under Test (EUT).

3.0 OPERATION

3.1 CONNECTIONS

Connect the EUT to the TEST STATION using an ADAPTOR and LENS RING from the selection provided. PLEASE NOTE that the unit can generate VERY HIGH PRESSURES and in consequence only METAL to METAL sealing is acceptable. i.e. NO SEALING WASHERS OF ANY DESCRIPTION SHOULD BE USED (see Figure 2 for methods of sealing).

3.2 BLEED AIR FROM SYSTEM

Ensure that H.P. Valve (1) and L.P. Valve (2) are both OPEN. i.e. turn fully counter-clockwise. Ensure that the Reservoir Valve (3) is still open. i.e. 4 turns counter-clockwise from the fully closed position. Wind Capstan fully IN clockwise. Note that air bubbles appear in the reservoir fluid. Wait for approximately 15 seconds and then wind Capstan fully OUT counter-clockwise again and wait for 60 seconds. Repeat the procedure until no more air is expelled into the reservoir fluid.

3.3 LOW PRESSURE PRIMING SEQUENCE

Close L.P. Valve (2) by fully turning clockwise. Wind IN the Capstan clockwise until resistance is felt and the Weight Carrier Tube Assembly rises. Note that more air may be expelled into the reservoir fluid during this operation due to the movement of the differential pistons within the Intensifier Unit. Adjust the height of the Weight Carrier Tube Assembly so that the bottom edge of the Carrier lies between the 2 red marks on the indicator rod (see Figure 3). Now rotate the Carrier in a clockwise direction at approximately 40 RPM by hand. The PRESSURE now generated by the DWT will be the pressure marked on the Carrier.

3.4 HIGH PRESSURE GENERATION MODE

Close H.P. Valve (1) fully clockwise, and open L.P. Valve (2) fully counter-clockwise. Wind Capstan fully OUT (counter-clockwise) and wait for 60 seconds. Wind Capstan fully IN (clockwise) and wait for 15 seconds. Wind Capstan fully OUT again (counter-clockwise) and wait a further 60 seconds. Close Reservoir Valve (3) fully clockwise.

THE DEADWEIGHT TESTER IS NOW READY FOR USE.

3.5 GENERATING CALIBRATION PRESSURE

To generate any required pressure select weights so that the SUM of ALL the weights (their pressure equivalents are marked on the top of each weight) PLUS the pressure marked on the Carrier is EQUAL to the pressure required. Load the weights onto the Carrier one at a time, ensuring correct location.

Generate pressure by winding the Capstan IN (clockwise) until the Weight Stack starts to rise. Spin the Weight Stack in a clockwise direction at approximately 40 RPM by using the palms of the hands on opposite side of the stack.

Adjust the height of the Weight Stack winding the Capstan IN or OUT until the bottom edge of the Carrier lies between the 2 red marks on the Indicator Rod (see Figure 3). Before ADDING or REMOVING WEIGHTS it is essential that the Weight Stack is no longer spinning.

NOTE: When reducing pressure ALWAYS use the Capstan (by winding OUT counter-clockwise) NEVER use any of the Valves.

When reducing pressure from High Pressure to Low Pressure by winding the Capstan fully OUT (counter-clockwise), some pressure is still retained in the system (approximately 700 psi / 50 bar). To release this pressure see note below.

IMPORTANT NOTE

To reduce pressure to ZERO wind the Capstan fully OUT anticlockwise. Open H.P. Valve fully counter-clockwise. Open Reservoir Valve (3) four turns anticlockwise.

4.0 MAINTENANCE

The M3800 Series of High Pressure Deadweight Testers have been designed to require minimal maintenance.

Routine maintenance entails keeping the unit clean and free from excess oil.

The operating fluid should be changed at regular intervals due to potential contamination from items under test. As soon as discoloration of the fluid is observed it should be replaced as soon as possible.

Note: If fluid contacts the skin, a mild allergic reaction may result. Wash at once with soap and water.

Should the PCU require inspection or cleaning, great care must be taken whilst handling the components.

4.1 PCU REMOVAL

Before removal of the PCU, the system pressure must be reduced to zero as described above.

Carefully lift off Weight Carrier Tube Assembly (G).

Unscrew Piston Nut B (F), and lift out Piston (E) – **take great care not to apply any side-loads to the piston to avoid possible breakage.**

Unscrew Piston Nut A (D), taking great care not to drop Cylinder, as it may be inside the assembly. (Note that Piston Nut A contains a bearing assembly, which is held in place by a snap-ring. This should not normally require any maintenance or additional lubrication).

Remove Cylinder (C).

The O Ring Seal (B) under the PCU can now be replaced if required.

4.2 CLEANING

Use “non-fluffing”, non-abrasive, lint-free tissue or absorbent cloth. Hold the Piston (E) by the larger “head” end, and rub the tissue back and forth along its length.

To remove all traces of contamination, the piston can be cleaned in a suitable solvent.

Note: O-ring seals should not be immersed in solvents, as they will become damaged. They should be wiped carefully with a new tissue.

After removal from the solvent, using a NEW tissue, repeat the cleaning procedure above.

Place piston carefully on a NEW tissue where it will not be damaged while the cylinder is cleaned.

IMPORTANT: NEVER TOUCH THE WORKING SURFACE OF A CLEAN PISTON WITH BARE FINGERS – THE NATURAL OIL IN YOUR SKIN CAN CAUSE THE PISTON AND CYLINDER TO STICK.

Wipe excess fluid from the outside surfaces of the cylinder (C).

Roll a NEW tissue into a tapered rod of appropriate size. Force the tissue through the cylinder bore whilst rotating. Ensure that the tissue is a tight fit inside the bore so that dirt and contamination is removed.

Repeat the above step, using a NEW tissue, but from the opposite end of the cylinder.

Immerse the cylinder in a suitable, clean solvent, then, using NEW tissues, repeat the cleaning procedure with the tapered tissue rolls.

4.3 REPLACEMENT

Ensure that the O Ring (B) is clean and undamaged, and that it is fitted correctly in the top of the PCU Column (A).

Place cylinder on top of the PCU Column, with the reduced diameter at the top, secure with Piston Nut A (D).

Hold the Piston by the larger "head" end, and dip the smaller "working" end into a container of CLEAN operating fluid. Transfer this to the top of Piston Nut A, and allow a few drops of the fluid to run through the bearing assembly and through the bore of the Cylinder. Repeat this 3 or 4 times to ensure a good film of fluid in the Cylinder.

CAREFULLY introduce the working end of the piston into the Cylinder – ensuring that it is held VERTICALLY, and push gently through.

NEVER FORCE THE PISTON INTO ITS CYLINDER OR DAMAGE WILL RESULT. If resistance is felt, introduce more fluid. If resistance continues, re-clean piston, cylinder or both. If, after repeated cleaning, the piston still will not slide freely within the cylinder, then permanent damage may have occurred. In which case, the parts should be returned to the factory for evaluation or replacement.

Screw Piston Nut B (F) onto Nut A to retain the Piston.

Carefully replace Weight Carrier Tube Assembly (G), ensuring that the central hole in the top locates correctly on the top of the Piston.

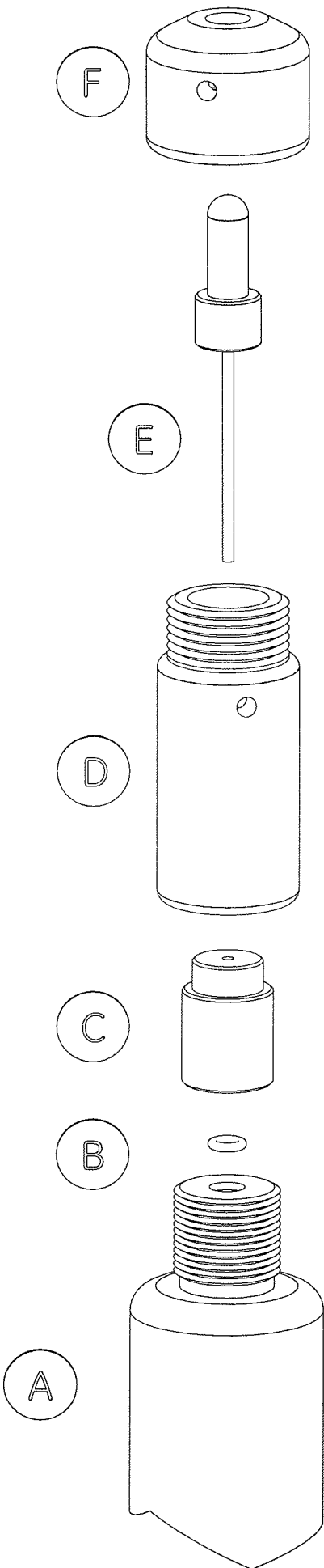

- A PCU MOUNTING COLUMN
- B O RING 54-903-007
- C CYLINDER
- D PISTON NUT A
- E PISTON
- F PISTON NUT B
- G WEIGHT CARRIER TUBE

HIGH PRESSURE PCU ASSEMBLY

5.0 RECALIBRATION

To maintain the highest accuracy the DWT should be recalibrated at regular intervals. The exact period between recalibrations is dependant on ambient conditions and use. As a general guide, recalibration period should be more than 1 year and less than 3 years.

DO's and DON'Ts: -

DON'Ts

DO NOT release high pressure using any of the valves – ALWAYS use the Capstan to reduce high pressure before opening any valve.

DO NOT rotate Weight Stack at its TOP or BOTTOM position.

DO NOT remove GRP cover.

DO NOT transport with fluid in the system.

DO NOT allow fluid to fall below recommended level.

DO's

DO change the operating fluid at the first sign of contamination.

DO have the Deadweight Tester and Weight Set recalibrated at regular intervals.

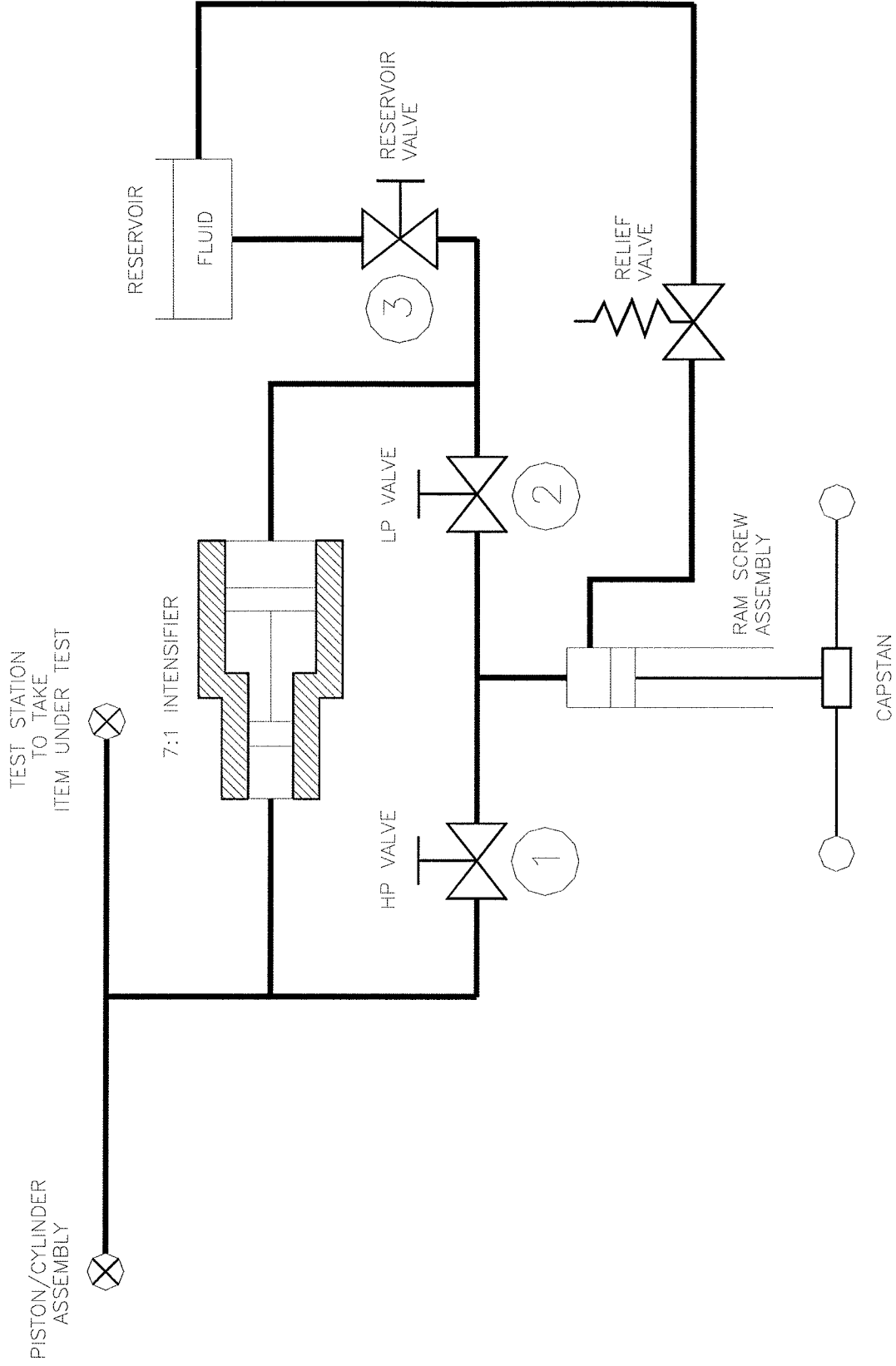
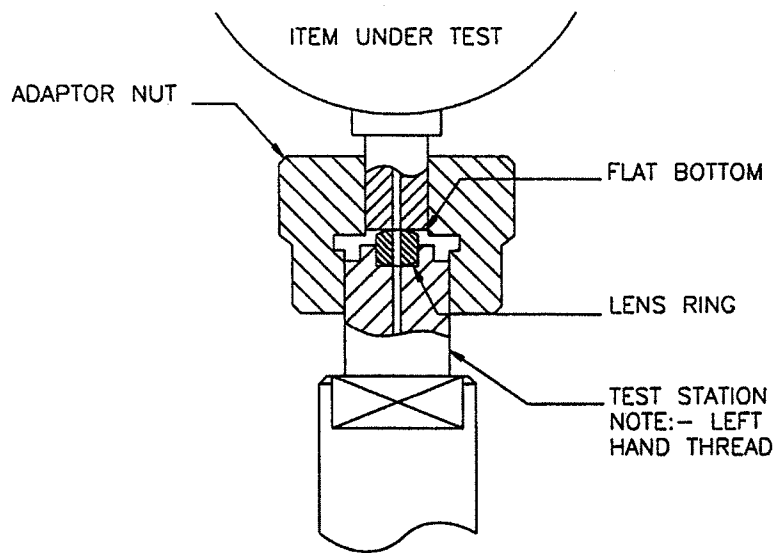
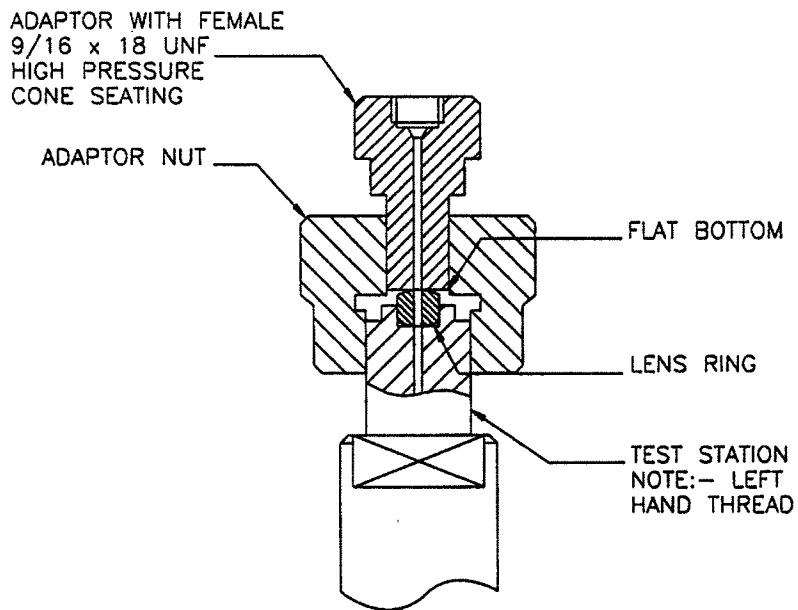

FIGURE 1. HYDRAULIC CIRCUIT SCHEMATIC



TYPE (1) METAL TO METAL SEAL
USING LENS RING AND FLAT BOTTOM
ON ITEM UNDER TEST



TYPE (2) METAL TO METAL SEAL
USING LENS RING AND HIGH PRESSURE
ADAPTOR WITH STANDARD CONE SEATING

Fig.2.....CONNECTIONS AND METHODS OF SEALING

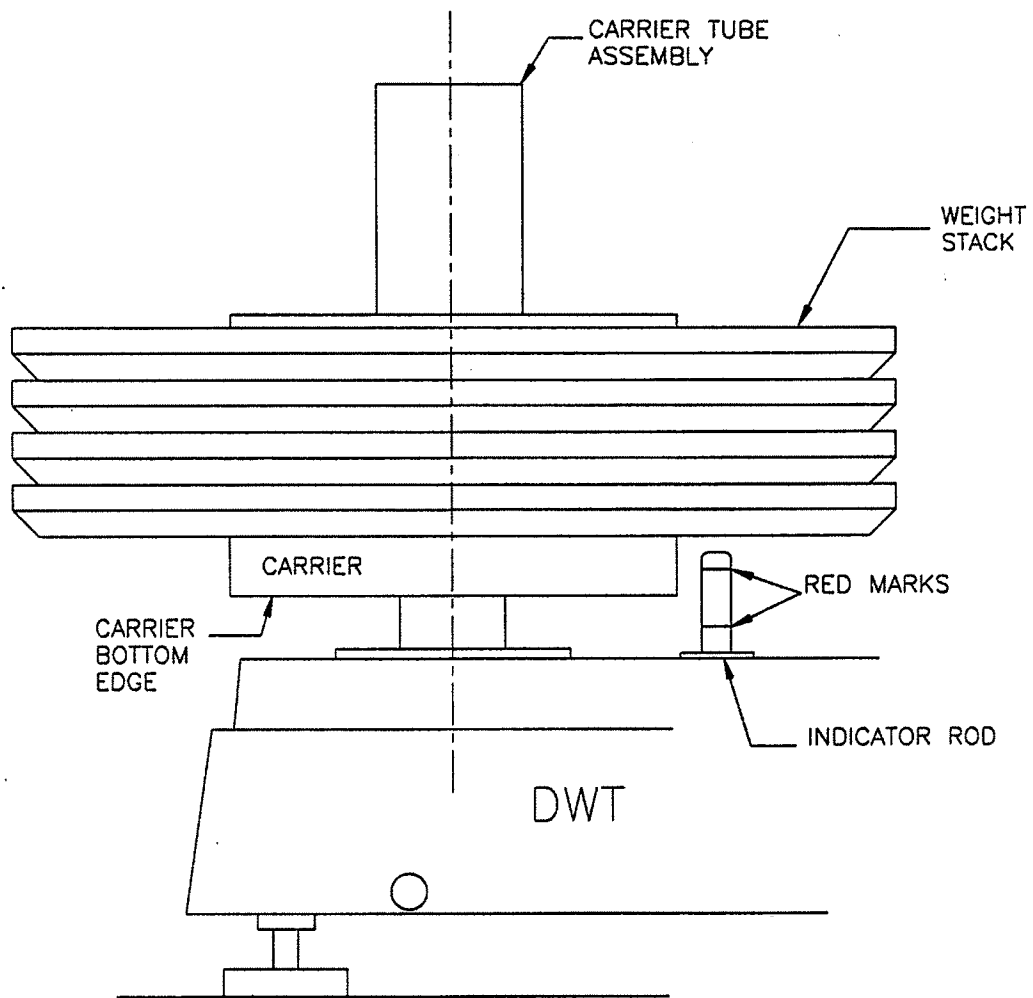

Fig.3....CORRECT FLOATING POSITION OF WEIGHT STACK

6.0 PRESSURE CORRECTIONS

Pressure correction is required for high accuracy work and is due to the effects of pressure on the PCU assembly during operation. By reference to the certificate of calibration provided the actual pressure in the system can be obtained. All values relate to the environmental conditions stated on the certificate.

The pressure in the system when the carrier is loaded with major weights can be read directly from the second column of the certificate.

The pressure in the system when the carrier is loaded with incremental weights is given together with the pressure in the system when the carrier is loaded with major and incremental weights. From these values, assuming effects are linear, the incremental weight corrections over the range may be calculated.

If the DWT is located at a position where the values of the gravitational acceleration and temperature of the operation are the same as those values specified for calibration, then the Actual Pressure is fully corrected. If the DWT is used under different conditions then further correction is necessary (see Figure 4). The reference level is specified on the certificate.

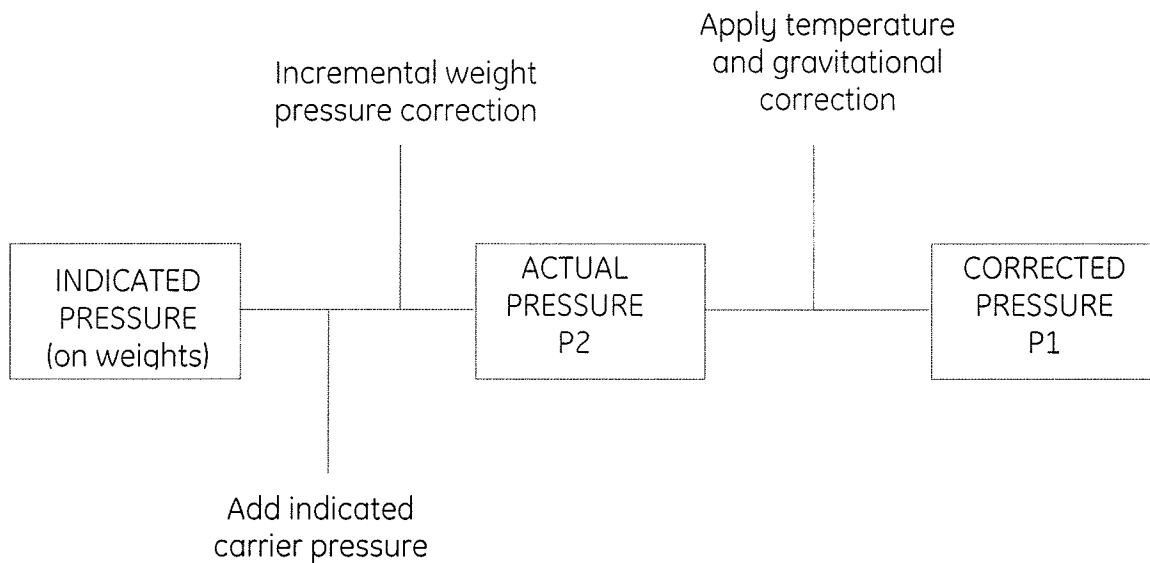

FIGURE 4
PRESSURE CORRECTIONS

Temperature and Gravity Corrections

Deadweight testers are manufactured to give an accurate pressure reference at the specified temperature and gravity values indicated on the certificates. The following Standard Values are applied during calibration unless otherwise requested during manufacture (see Certificate).

Standard Gravitational acceleration (G)	9.80665 m/s ²
Standard Temperature (T)	20°C

$$P_1 = P_2 \left(1 + \alpha (T - t) \right) \frac{g}{G}$$

Where:

P_1 = Corrected Pressure

P_2 = ACTUAL PRESSURE

α = Coefficient of Linear Expansion

(The value for a specific piston / cylinder assembly (PCU) is shown on the Calibration Certificate)

T = DWT calibrated temperature (°C)

t = Temperature at position of DWT (°C)

g = Gravitational acceleration at position of DWT

G = DWT calibrated gravitational acceleration

The value of gravitational acceleration (g) varies with latitude, height above sea level and geological conditions at the location of the DWT. When the gravitational acceleration varies from that for which the DWT was calibrated, the above correction must be made. The local value of gravitational acceleration (g) can be obtained as follows:

Data from the appropriate geophysical authority

Approximated from the Nomogram (Figure 5).

Calculated from the formula:

$$g = 9.7803184 \left(1 + 0.0053024 \sin^2 L - 0.0000059 \sin^2 2L \right) - 0.0000038086 H$$

Where

L = geographical latitude, H = height above sea level in meters and units of g are m/s²

Height Corrections

Tests carried out at locations other than the test stations may require corrections for fluid heights. The pressure exerted by a column of fluid 1" / 25.4 mm high will not exceed 0.036 psi / 0.0025 bar using the recommended fluids.

Explanation of Nomogram
 A straight line passing through the known values of altitude (H) and latitude (L) of the site of the DWT, when extended to scale 'g', will indicate the approximate value of 'g'.

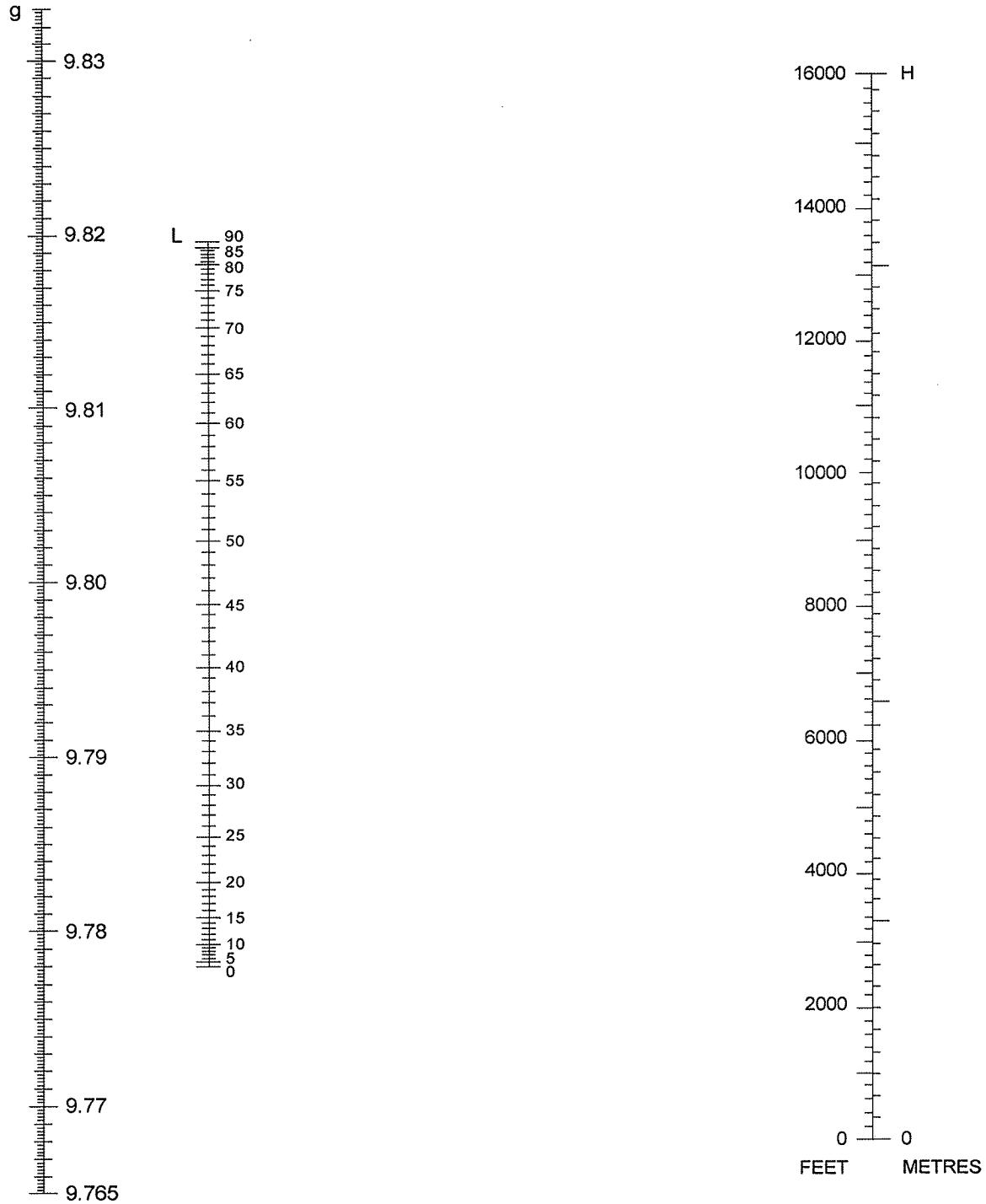

FIGURE 5
 NOMOGRAM FOR FINDING THE VALUE OF "g" FROM ALTITUDE AND LATITUDE